

SSE135/SSE135L

SSE160/SSE160L



The Stratos SSE machines have been developed for applications where it may be desirable for the operator to work in a fully enclosed cab, while maintaining a standing position for speed and flexibility. The trucks offer a capacity of 1350 and 1600 kg and a maximum lift height of 6.3 m.



Technical Details		SSE135/SSE135L	SSE160/SSE160L
Power unit		electrical, battery	electrical, battery
Operating type		stand on	stand on
Rated capacity	kg	1350	1600
Load centre	mm	600	600
Max. axle load castor/drive wheels			
without load	kg	430/580 ¹⁾	615/770 ²⁾
with rated load	kg	475/680 ¹⁾	640/795 ²⁾
Max. axle load supp.wheels			
without load	kg	410 ¹⁾	730 ²⁾
with rated load	kg	1600 ¹⁾	2230 ²⁾
Wheel type, front/rear		polyurethane	polyurethane
dimension, front/rear	mm	Ø 85/250	Ø 85/250
Travel speed, without/with rated load		9,0/7,6	9,0/7,6
Lift speed, without/with rated load		0,30/0,20	0,25/0,15
Lowering speed, without/with rated load		0,30/0,45	0,40/0,46
Gradient, without/with rated load		16/8	12/6
Service brake		electric	electric
Parking brake		Autom. electr.	Autom. electr.
Drive motor/Intermittent rating	kW/%	1,8/60	1,8/60
Lift motor/Intermittent rating	kW/%	5,0/20	5,0/20
Steering system		electronic	electronic
Speed control, number of steps		transistor, stepless	transistor, stepless
Number of steering wheel turnings		endless	endless

1) SSE135, h₃ 3350, battery 300 Ah

2) SSE160L, h₃ 6300, battery 360 Ah

Dimensions, mm		SSE135	SSE135L	SSE160	SSE160L
x	Front axle to fork front face Duplex/Triplex	827/809	830/812	782/782	785/785
h ₆	Height of truck	2290	2290	2290	2290
h ₇	Instep height	245	245	245	245
h ₁₃	Height of lowered fork	90	90	90	90
l ₂	Truck length incl. back of fork short chassis, Duplex/Triplex long chassis, Duplex/Triplex	919/938 1033/1052	960/979 1074/1093	— 1079/1079	— 1120/1120
b ₁	Chassis, width Width with stabilizers	900 940	945 1040	900 940	945 1040
e	Fork width	180	180	180	180
l	Fork length	1150	1150	1150	1150
b ₅	Width across fork	570	570	570	570
m ₁	Floor clearance	28	28	28	28
W _a	Turning radius short chassis long chassis	1785 1898	1829 1941	— 1898	— 1941
A _{st}	Aisle width short chassis, Duplex/Triplex long chassis, Duplex/Triplex	2532/2544 2645/2657	2573/2586 2685/2698	— 2677/2677	— 2717/2717

Truck performance and dimensions are nominal and subject to tolerances.
BT Products AB products and specifications are subject to change without notice.
All data is based on VDI 2198.

SSE135L/SSE160L

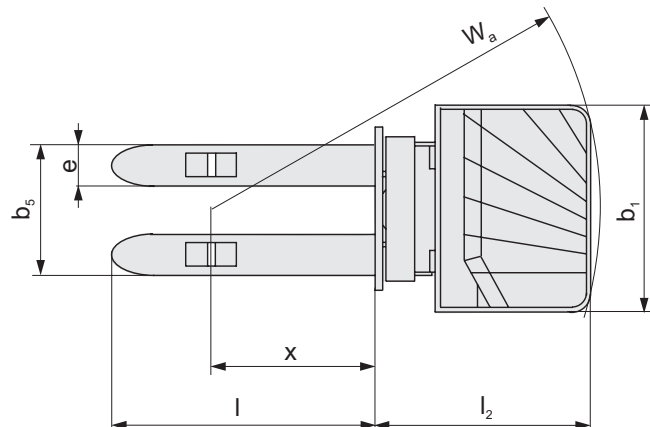
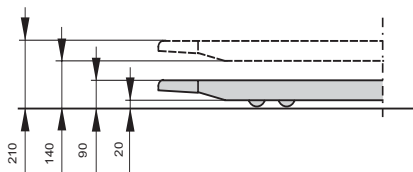

Mast			SSE135/SSE135L								
h_3	Lift height	mm	2800	2900	3350	3750	4150	4150	4500	4800	5400
Duplex Tele											
h_1	Height of mast, min. ¹⁾	mm	1937		2212	2422	2622				
h_2	Free lift	mm	—		—	—	—				
h_4	Height of mast, max. ¹⁾	mm	3317		3867	4277	4677				
Duplex Hi-Lo											
h_1	Height of mast, min. ¹⁾	mm		1987	2212	2422	2622				
h_2	Free lift	mm		1518	1743	1943	2143				
h_4	Height of mast, max. ¹⁾	mm		3417	3867	4277	4677				
Triplex Hi-Lo											
h_1	Height of mast, min. ¹⁾	mm						1948	2065	2165	2365
h_2	Free lift	mm						1476	1592	1692	1892
h_4	Height of mast, max. ¹⁾	mm						4670	5021	5321	5921
	Weight without battery ²⁾	kg	1230	1255	1290	1315	1375	1405	1445	1465	1520
	Battery (5h discharge), min./max.	V/Ah	24/300—600								
	Battery weight, min./max.	kg	250—530								

Mast			SSE160/SSE160L								
h_3	Lift height	mm	2900	3350	3750	4150	4400	4800	5400	5700	6300
Duplex Tele											
h_1	Height of mast, min. ¹⁾	mm	2013	2238	2438	2638					
h_2	Free lift	mm	—	—	—	—					
h_4	Height of mast, max. ¹⁾	mm	3443	3893	4293	4693					
Duplex Hi-Lo											
h_1	Height of mast, min. ¹⁾	mm	2013	2238	2438	2638					
h_2	Free lift	mm	1518	1743	1943	2143					
h_4	Height of mast, max. ¹⁾	mm	3443	3893	4293	4693					
Triplex Hi-Lo											
h_1	Height of mast, min. ¹⁾	mm					2075	2208	2408	2508	2708
h_2	Free lift	mm					1465	1598	1798	1898	2098
h_4	Height of mast, max. ¹⁾	mm					5058	5458	6058	6358	6958
	Weight without battery	kg	1230	1255	1290	1315	1375	1405	1445	1465	1520
	Battery (5h discharge), min./max.	V/Ah	24/360—600								
	Battery weight, min./max.	kg	370—530								

1) Mast height +120 mm with raised support arms

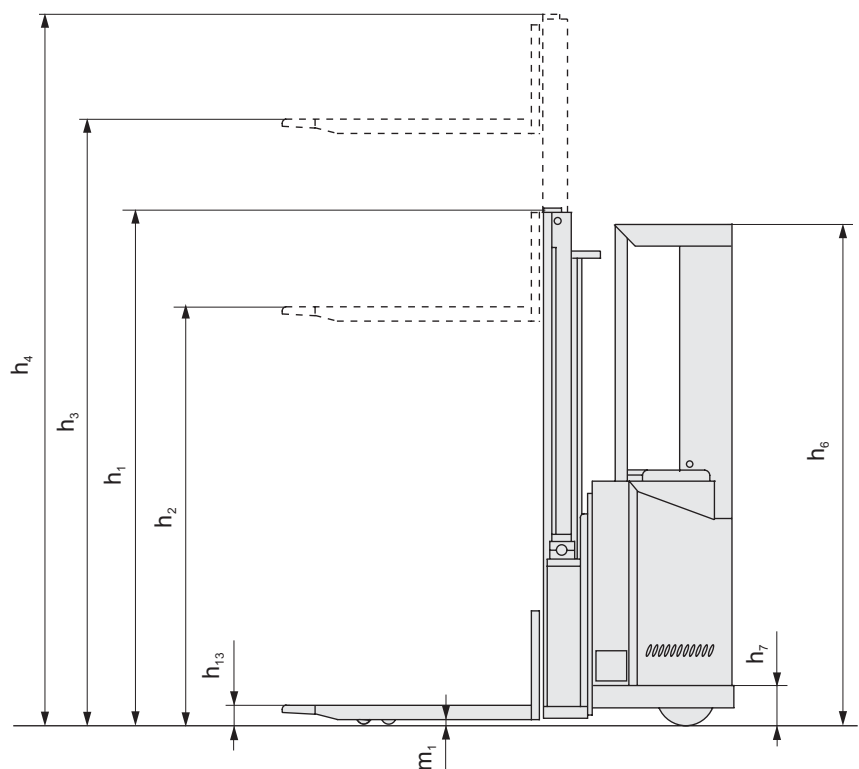



- Transversely standing driver gives the best and most comfortable driving position in both directions of travel.
- Clear view mast and overhead guard enables safe load handling at all heights. The visibility window also ensures excellent visibility in pallet transport.
- Two pallet handling. Two separate loads may be carried at the same time — 675kg on the support arms, 675kg on the fork (SSE135L) — 800kg on the support arms, 800kg on the fork (SSE160L). Lift height is then maximized to 1200mm.
- The battery is standing on rollers with a built in battery table, allowing easy access for inspection and also facilitating fast sideways battery change.
- Programmable performance — acceleration rate, maximum travel speed and steering sensitivity.

Truck features	SSE135	SSE135L	SSE160	SSE160L
Bogie fork wheels	S	S	S	S
Double pallet handling	—	S	—	S
Elevating support arms	—	S	—	S
Controls and instruments				
Fingertip controls	S	S	S	S
Hour meter	S	S	S	S
Power/Electronic steering	S	S	S	S
Driving features				
Electronic braking system	S	S	S	S
Electronic speed control	S	S	S	S
Safety features				
Automatic parking brake	S	S	S	S
Clear-view mast	S	S	S	S
Driver detection system	S	S	S	S
Emergency cut-off	S	S	S	S
Load support	O	O	O	O
Drivers compartment features				
Low step-in	S	S	S	S
Maintenance features				
Easy access for maintenance	S	S	S	S
Fault diagnosis facility	S	S	S	S
History fault log	S	S	S	S
Battery management features				
Battery status indicator	S	S	S	S
Sideways battery change	S	S	S	S
Heavy duty battery compartments	O	O	O	O

S = Standard feature

O = Optional feature

— = Not available